

Dresser Series B3-HPC Meter High Pressure Cartridge (HPC) Meters

1M740/1480 | 3M740/1480 | 5M1480 | 7M1480 | 11M1480

Dresser Measurement High Pressure Cartridge Meters incorporate several design innovations in rotary meter measurement. Advancements to the time-tested and accepted Dresser Meters provide accurate and reliable measurement solutions compared to other obsolete positive displacement style meters, oversized inferential style meters, and other styles of insertion inferential meters.

Description

Series B3-HPC Rotary Meters employ the same positive displacement operating principle as other Dresser rotary meters. Gas volumes are measured by two figure-8 impellers rotating in a chamber of known volume. Precision machining to exact tolerances ensures measurement accuracy, while materials of construction promote high quality measurement performance in the most severe conditions.

1M and 3M measurement cartridges are interchangeable between their common body casting, as are the 5M and 7M versions. This allows the operator to “right-size” the meter for a particular application. Also, accuracy certified cartridges are field replaceable for ease of maintenance. The new 11M1480 has a 4” ANSI 600# flanged connection and, the 11M cartridge is not interchangeable with other HPC meter sizes.

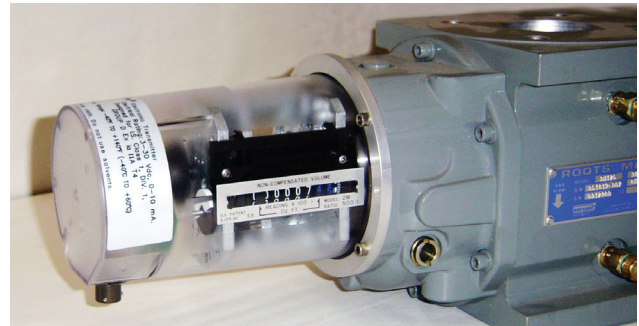

Figure 1 - 11M1480 with Integral Micro Corrector, 7M1480 with ID mount, inset ICEX accessory unit.

An optional full capacity internal bypass is available for the 1M, 3M, 5M and 7M Series B3-HPC cartridges. The bypass for the 11M1480 is currently under development. Since the bypass is self-resetting, an optional electronic/mechanical differential pressure sensor with a switched output is available to indicate if the meter has been in the bypass mode.

NOTE: The 11M1480 is capable of metric measurement by utilizing an IMC/W2 as an accessory unit.

The Bypass Valve is an optional feature for our HPC meters

The optional BPV (Bypass Valve) is a robust design with self-resealing edges. It is always closed unless the differential pressure exceeds the spring rate and lets the gas flow through the bypass, whether in a short burst or full flow – if the meter locks up. The valve opens due to high differential and allows gas to flow around the measuring chamber to keep the customer on line with gas supply.

An optional analog indicator with a follower needle visually displays that the bypass has opened. This indicator is useful to determine if the meter has gone into a bypass condition, as it has an integral reed switch and flying leads that can be wired into any pulse receiving device that can alert the end user of an alarm condition.

The bypass valve opens when meter differential reaches 6.5 psi (180 in. H₂O), as tested with Natural Gas on the 1M and 3M, and 7.2 psi (200 in. H₂O) for the 5M and 7M.

Applications

- The High Pressure Cartridge design meters are ideal for gas measurement of low volume applications at high pressures. Recommended applications include:
- Custody transfer (gas distribution, gathering, and transmission systems)
- Town border stations and city gate stations
- Direct wellhead production measurement
- Gas leg of production separators and test separators
- Compressor fuel gas measurement
- High pressure industrial gas measurement

Standards

As with all Dresser meters, the High Pressure Cartridge meters are designed to ANSI B109.3 specifications for Rotary Type Gas Displacement Meters. Additionally, the HPC meters meet NACE Standard MR 111075 for corrosion resistant applications.

Meter Advantages

- Operating differentials can be monitored while in service
- Positive displacement measurement is not sensitive to changes in density of the gas being measured
- Positive displacement meters (side or top inlet) do not require a complicated installation since they are not sensitive to velocity profiles
- Meter body and flanges are rated at 1480 psig (740 psig optional for 1M and 3M)
- Meters are designed to NACE corrosion resistance standards
- Meters are compatible with a wide assortment of pulsing devices and auxiliary instrumentation for Dresser products

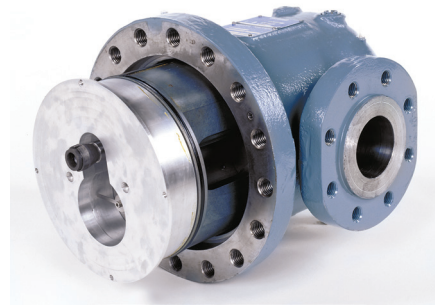

Cartridge Advantages

- Cartridge design simplifies repair and maintenance
- Calibrated cartridges can be installed in the field – reducing downtime
- Cartridges can be replaced in the field without removing the meter housing
- Cartridges are interchangeable as measurement needs change

Optional Bypass Valve Features

- Full capacity and internal
- Simple design
- Optional Indicator with switched output
- Spring-loaded valve
- Fits onto any standard housing - Interchangeable
- Self-resetting
- Passes full flow at any pressure

Technical Specifications

	1M740/1480	3M740/1480	5M1480	7M1480	11M1480
Maximum Capacity	1000 cfh	3000 cfh	5000 cfh	7000 cfh	11000 cfh
Oil Capacity					
Side Inlet	4.2 oz (124 ml)	2.8 oz (83 ml)	17.5 oz (518 ml)	13.5 oz (399 ml)	14 oz (414 ml)
Top Inlet	11 oz (325 ml)	7.2 oz (213 ml)	37 oz (1094 ml)	29 oz (858 ml)	34 oz (1006 ml)
Maximum Allowable Pressure Rating (Optional)	1480 psig (ANSI 600) 740 psig (ANSI 300)	1480 psig (ANSI 600) 740 psig (ANSI 300)	1480 psig (ANSI 600)	1480 psig (ANSI 600)	1480 psig (ANSI 600)
Connection Size	2" (50 mm) RF	2" (50 mm) RF	3" (80 mm) RF	3" (80 mm) RF	4" (100 mm) RF
Temperature Rating	-40°F to +140° F	-40°F to +140° F	-40°F to +140° F	-40°F to +140° F	-40°F to +140° F
Piping Configuration	Top or Side Inlet	Top or Side Inlet	Top or Side Inlet	Top or Side Inlet	Top or Side Inlet
Drive Rate	10 cf/rev (0,1 m ³ /rev)	10 cf/rev (0,1 m ³ /rev)	10 cf/rev (1 m ³ /rev)	10 cf/rev (1 m ³ /rev)	10 cf/rev (NA)

Sizing Table

Meter Size	1M	3M	5M	7M	11M
Meter Capacity (acfh)	1000	3000	5000	7000	11000
Pressure (psig)	Meter Capacity at Pressure (scfh)				
0.25	995	2,984	4,973	6,962	10,940
100	7,766	23,299	38,832	54,365	85,426
600	41,711	125,132	208,554	291,976	458,810
800	55,289	165,866	276,443	387,020	608,190
1000	68,866	206,599	344,331	482,064	757,570
1200	82,444	247,332	412,220	577,108	906,840
1400	96,022	288,065	480,109	672,152	1,056,220
1480	101,453	304,358	507,264	710,170	1,115,980

NOTE: All capacities listed are Standard Cubic Feet per Hour (SCFH) and based upon Average Atmospheric Pressure (14.4 PSIA), Base Pressure (14.73 PSIA), and Base Temperature (60°F). Tables do not take into account supercompressibility. Please refer to RM-135 for further information on the Application of Temperature and/or Pressure Correction Factors in Gas Measurement.

Dimensions

Version	Overall Length		Overall Height		Width (flange/flange)		Centerline to Accessory End (CL-AU)		Drawing Number
	in	mm	in	mm	in	mm	in	mm	
1M/3M									
CTR	16-1/32	407					10-1/4	260	D054757-000
CD	19-27/32	504					14-1/16	358	D054434-000
ICPW/ICEX	17-19/32	447	8-5/8	218	10-3/4	273	11-3/16	300	D057373-000
IMC/W2	19-21/32	499					13-7/8	352	D059145-000
5M/7M									
CTR	19-9/32	490					12-13/32	315	D056135-000
CD	23-3/32	587					16-13/16	412	D056136-000
ICPW/ICEX	21-7/32	539	14-9/32	363	14-3/4	375	14-5/16	364	D057442-000
IMC/W2	22-29/32	582					16-1/32	407	D059146-000
11M									
CTR	23-7/8	606					14-11/16	373	D059633-000
CD	27-11/16	703					18-1/2	470	D059329-000
ICPW/ICEX	25-13/16	655	14-9/32	363	14-3/4	375	16-5/8	422	D059535-000
IMC/W2	27-1/2	699					18-5/16	465	D059374-000

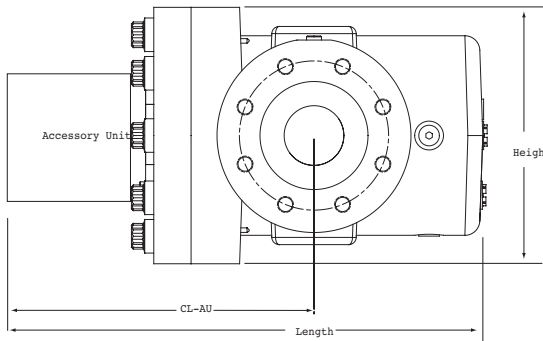

How to Order: Specify Dresser Series B3-HPC Meter, 1M1480 or 3M1480 (optional: 1M740 or 3M740), 5M1480, 7M1480 or 11M1480 plus the Accessory Type.

Accessory Types: Series 3 Counter (CTR), Counter with Instrument Drive (CD), or Counter with Solid State Pulser (CPWS - Single Connector, CPWD - Dual Connector available with MS Circular Connector(s) or Cable Gland Connection, or Conduit Connection). For the CD option, specify Top or Side Inlet and Clockwise (B) or Counterclockwise (A) rotation.



International Measurement and Control Systems

Distributed by:
 IMAC Systems, Inc.
 90 Main Street, Tullytown, PA. 19007
 t: 215 946-2200 f: 215 943-2984
 e: sales@imacsystems.com
 www.imacsystems.com

© 2021 Natural Gas Solutions North America, LLC – All rights reserved. Dresser Utility Solutions reserves the right to make changes in specifications and features shown herein, or discontinue the product described at any time without notice or obligation. Contact your Dresser Utility Solutions representative for the most current information. The Dresser Logo and all Trademarks containing the term "Dresser" are the property of Dresser, LLC, a subsidiary of Baker Hughes.