

GT, GTS, GTX and AccuTest Turbine Gas Meters

Technical Bulletin



Distributed By:
IMAC Systems, Inc.
90 Main Street / PO Box 1605
Tullytown, PA. 19007
Tel: 800 955-4427 / 215 946-2200
Fax: 215 943-2984
www.imacsystems.com



elster
American Meter

The turbine meters are designed to accurately measure natural gas, air, nitrogen, carbon dioxide, propane vapor, and other non-corrosive gases for large volume commercial and industrial uses.

General Information

Meters are available in sizes ranging from 3" up to 12". Inlet pressures up to 1480 PSIG. Operating temperature range is -40°F to 140°F. (-40°C to 60°C). Maximum flow rates at 7" Water Column pressure (.60 Specific Gravity Gas) are:

- 3" – 10,000 SCFH
- 4" – 18,000 SCFH
- 6" – 35,000 SCFH
- 8" – 60,000 SCFH
- 12" – 150,000 SCFH

Meters meet manufacturing standards as specified in ANSI/ASME/AGA Report Number 7.

Features

Maximum allowable operating pressures (MAOP) – from 175 PSIG up to 1480 PSIG.

Body Materials – Cast aluminum, cast steel, or steel depending on pressure rating.

English or metric units of measurement.

Common gear train for 3", 4", 6" and 8" meter sizes thereby reducing spare parts inventory.

Interchangeable pre-calibrated measurement cartridges allow for easy maintenance.

High efficiency inlet Flo-Guide conditioners minimize the effects of flow disturbances in short coupled installations.

GTX model utilizes permanently lubricated bearings for maintenance free use.

AccuTest model incorporates two independent measuring cartridges in one housing, both calibrated to allow proving the meter while in service with ATP software.

Applications

Model	Description
GT	Basic turbine meter, downstream rotor, integral Flo-Guides®, flush-type lubrication system cleans main bearings while meter is in operation, available in 3" and 12".
GTS	Basic turbine meter, pre-machined housings to allow upgrade to AccuTest self-test model, flush-type lubrication system cleans main bearings while meter is in operation, both inlet and outlet Flo-Guides, available in 4", 6" and 8".
GTX	Economic turbine meter, permanently lubricated main bearings, inlet Flo-Guide®, available in 4", 6", and 8".
AccuTest	Self-proving turbine meter, both inlet and outlet Flo-Guides®, flush-type lubrication system cleans main bearings while meter is in operation, two high frequency RF-type pulsers, secondary reference cartridge, aluminum main and reference rotors, available in 4", 6", and 8" pipe sizes.

Options

Extended Capacity Ratings

Standard capacity ranges available for all sizes and models. The 4", 6", and 8" GTS and AccuTest turbine meters can utilize a 30° rotor to increase the capacity over the standard 45° rotor.



Rotor Materials

Available in either plastic or metal (Metal must be used for high frequency RF pulser).

	3"	4"	6"	8"	12"
45°Plastic	45°Plastic	45°Plastic	45°Plastic	45°Plastic	45°Plastic
	45°Metal	45°Metal	45°Metal		
	30°Metal	30°Metal	30°Metal		



Volume Registration Outputs

The turbine meters come with several outputs: mechanical drive with index, mechanical drive with no index or mechanical drive and electronic (RF, RVP, MFP) pulse output.

Pressure Ratings

Size	MAOP PSIG (bar)	Material	
		Housing	Top
3"	275 (19)	Aluminum	NA
	1480 (100)	Steel	NA
4"	175 (12)	Aluminum	Aluminum
	740 (50)	Cast Steel	Steel
	1480 (100)	Cast Steel	Steel
6"	175 (12)	Aluminum	Aluminum
	740 (50)	Cast Steel	Steel
	1480 (100)	Cast Steel	Steel
8"	175 (12)	Aluminum	Aluminum
	740 (50)	Cast Steel	Steel
	1480 (100)	Cast Steel	Steel
12"	175 (12)	Steel	Aluminum
	275 (19)	Steel	Steel
	740 (50)	Steel	Steel
	1480 (100)	Steel	Steel



Indexes

Available in either English or metric units of volume with circle type or odometer type indexes.

Pulse Outputs

Pulsers can be furnished with the meter.

	3"	4"	6"	8"	12"
	Low Frequency				
	Remote Volume Pulser (RVP)				
	Medium Frequency				
GT Only	All Models			GT Only	
	RF Pulser				
N/A	GTS and AccuTest			N/A	



Extended Width (E-Class) Housing

The 4", 6" and 8" turbine meters are available with an extended width housing. The 4" E-Class is available in all pressure ratings while the 6" and 8" E-Class Housings are available in either 175 or 740 PSIG working pressures.

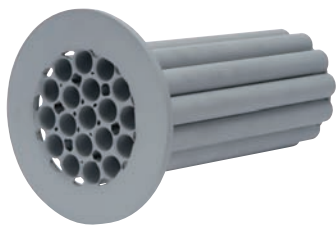

Straightening Vanes

Straightening Vanes are recommended by the A.G.A. Report No. 7 as a means to condition the gas flow to a normal pattern, enabling accurate measurement by the downstream turbine meter.

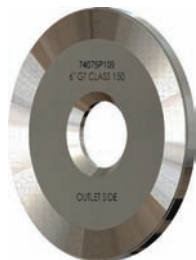

Restrictor Plate

Restrictor plates limit the flow rate through the meter and prevent overspeeding of the rotor. They are normally installed 5 pipe diameters downstream of the meter between flanges.



Lubrication

Turbine meters require routine maintenance, including lubrication, to insure measurement accuracy and enhance the service life of the meter. Two types of lubrication pump kits are available depending on the working pressure of the meter. For meters operating up to 500 PSIG, a plunger-type pump is available (Part Number 93723K002). For meters operating over 500 PSIG, use the single speed hydraulic hand pump (Part Number 93723K001).



AccuTest Field Prover

The AccuTest Field Prover includes the sensor cables, signal conditioner in a case, DAQ card, computer interface cable, and software program.

Accuracy Curves

The accuracy of the turbine meter can be determined by low, medium, and high-pressure test facilities.

Low Pressure

- 350 cubic foot Bell Prover
- Large Sonic Nozzle provers
- 5 point accuracy curve standard



Medium Pressure

- 120 PSIG recirculating air test loop
- Master turbine meters used as reference
- 6 point accuracy curve standard
- (30 PSIG to 120 PSIG – air)

High Pressure

- Pressures up to 1480 PSIG
- Master turbine meters or sonic nozzles used as reference
- 6 point accuracy curve standard

All facilities are available for recertification of existing meters.



Flow Computer RF Interface Kit

This kit allows the use of a single RF sensor to detect movement of the rotor.

Theory of Operation

Gas measurement in the U.S. and around the world is dominated by diaphragm, rotary, turbine, and orifice meters. Each serves a different segment of the gas industry and each has its own set of advantages and disadvantages.

These four main types of meters can be broken into two distinct categories: positive displacement, and inferential. Diaphragm and rotary meters fall into the positive displacement group because they have well-defined measurement compartments that alternately fill and empty as the meter rotates. By knowing the volume displaced in each meter revolution and by applying the proper gear ratio, the meter will read directly in cubic feet or cubic meters.

Turbine and orifice meters have no measurement compartments to trap and then release the gas. These meters are categorized as inferential meters in that the volume passed through them is "inferred" by something else observed or measured. In the orifice meter the volumes are determined by knowing the inlet pressure, differential pressure, plate size, and piping characteristics, all of which "infer" the flow rates that in turn can be integrated over time to provide the volume.

Turbine meters, also called velocity meters, "infer" the volume of gas passing through them by measuring the velocity of the gas stream. Gas moving through the meter impinges on rotor blades resulting in a rotational speed that is proportional to the flow rate. The volume is determined by counting the number of meter rotations.

As defined in A.G.A. Report #7, the turbine meter consists of three basic components:

1. The body which houses all of the parts and physically contains the gas pressure.
2. The measuring mechanism consisting of the rotor, rotor shaft, bearings, and necessary supporting structure.
3. The output and readout device which may be either a mechanical drive to transmit the indicated meter revolutions outside the body for uncorrected volume registrations or for electrical pulse meters, it would be the pulse detector system and all electrical connections needed to transmit the pulses outside.

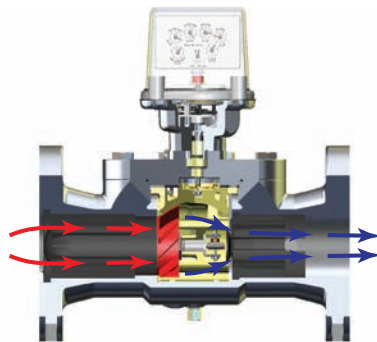

Gas entering the meter increases in velocity as it flows through the annular passage formed by the nose cone or upstream stator and the interior of the body. The movement of the gas over the angled rotor blades exerts a force to the rotor causing it to rotate. The ideal rotational speed of the rotor is directly proportional to the flow rate of the gas. The actual rotational speed is a function of the annular passageway size and shape, and rotor design. It is also dependent on the load that is imposed due to internal mechanical friction, fluid drag, external loading, and gas density.

A.G.A. Report #7 was written to provide recommendations as to the correct method for installing turbine meters, using their associated corrective factors, and meeting the operating requirements that pertain to axial flow type meters. Since the turbine meter is a velocity-measuring device, consideration should be given to both the upstream and downstream piping to insure a uniform velocity distribution of the gas through the meter and the rotor by reducing jetting or swirl. Construction of the turbine meter is such so as to minimize minor flow distortions that could affect meter performance. See Figure 1.

The AccuTest turbine meter utilizes a second cartridge downstream of the first or main rotor. This rotor has vanes with a different blade angle and rotates in the opposite direction of the main rotor. Since both rotors are measuring the same flow rate of gas at the same temperature and pressure, then the output registration should be the same off of both rotors. In effect, the meter is a built-in transfer prover to continuously monitor its condition.

A laptop computer, with inputs from both rotor sensors, multiplies the ratio of pulse frequencies by the ratio of the calibration (K) factors to compute meter accuracy.

$$\text{Accuracy} = \frac{\text{Frequency of main rotor}}{\text{Frequency of reference rotor}} \times \frac{\text{K Factor of reference rotor}}{\text{K Factor of main rotor}}$$

Figure 1

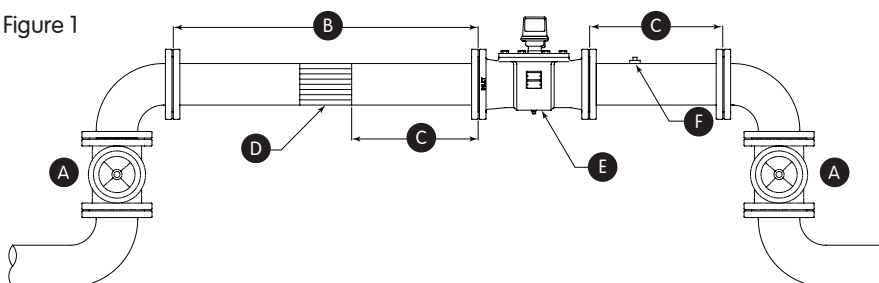

- Ⓐ Optional Valve
- Ⓑ 10 Nominal Pipe Diameters
- Ⓒ 5 Nominal Pipe Diameters
- Ⓓ Straightening Vanes
- Ⓔ Turbine Meter
- Ⓕ Temperature Well (Downstream)

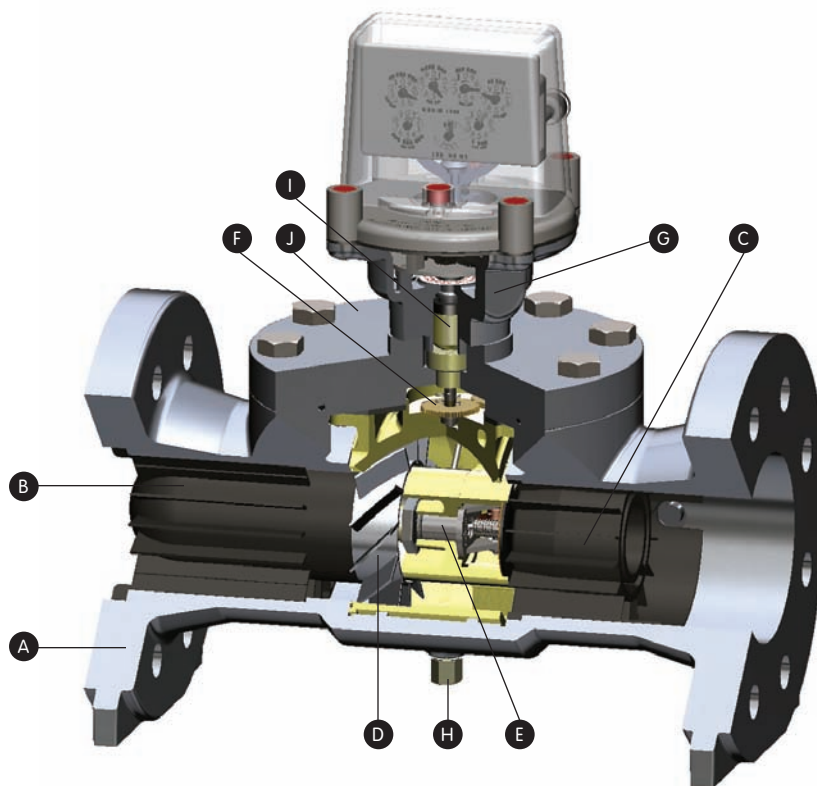

Material Specifications

- A** Housing - Aluminum for pressures up to 275 PSIG. Cast Steel for pressures greater than 275 PSIG. Steel for all 12" housings. 3" housing is clamped (wafer style) between ANSI flanges. 4" through 12" housings are ANSI flanged.
- B** Inlet Flo-Guide® - Black Stanyl TW241F10. 12" GT uses an aluminum Flo-Guide®.
- C** Outlet Flo-Guide® - Black Stanyl TW241F10. Not available on GTX meter. 12" GT uses an aluminum Flo-Guide®.

D Rotor -

Angle	Material	Used on
45°	Plastic	All
45°	Aluminum	4", 6" & 8"
30°	Aluminum	4", 6" & 8"

Rotor is located downstream on 3" GT and 12" GT meters. GT and GTX meters are only available with a 45° plastic rotor. GTS meters available with a 45° or 30° rotor in either plastic or aluminum.

- E** Flush-type Lubrication System. System has an internal reservoir that continuously lubricates the main rotor shaft while in operation. Available on GT, GTS and AccuTest meters.

- F** Intermediate Gears - Brass, Designed for each specific meter size and rotor angle.
- G** Gear Train Assembly - Delrin gears, Provides mechanical output drive to an index or corrector.
- H** 1/4" NPT Drain Plug - Steel, zinc plated and yellow chromate.
- I** Magnetic Drive Interface - Isolates high pressure components eliminating the need for seals.
- J** Top Plate - Aluminum, for working pressures of 125 and 275 PSIG. Steel, for working pressures of 740 and 1480 PSIG.

- K** Reference Rotor - Aluminum, AccuTest meter only.
- L** RF Sensor Assembly - Stainless Steel, Standard on AccuTest, optional on 4", 6" and 8" GTS meters.
- M** Pressure Tap - Senses pressure at the rotor. AccuTest and GTS meters only.
- N** Lubrication Fitting - GT, GTS and AccuTest meters only.

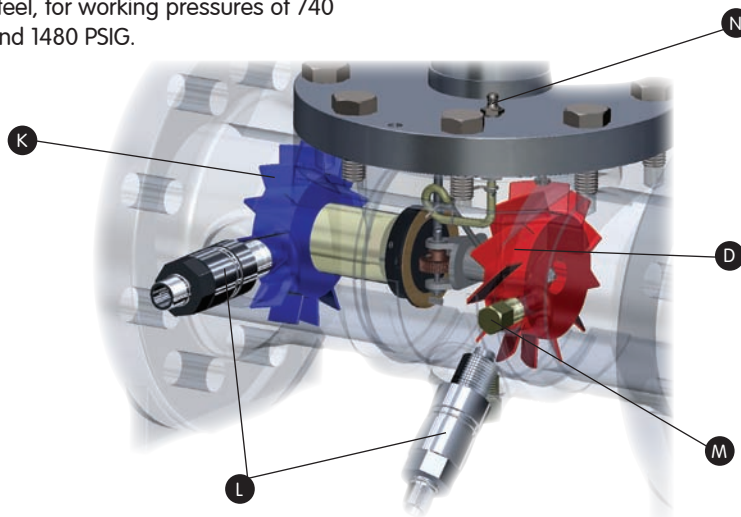

GT, GTS, GTX and AccuTest Turbine Meters Capacity Performance

3" GT, Output Drive = 100 Cubic Feet, 45° Rotor

Line Pressure (PSIG)	Qmax MSCFH	Qmin MSCFH	Range Qmax/Qmin	Min. Actual Flow Rate MACFH	Press. Drop in W.C.
0.25	10	0.8	12	0.83	4.5
5	13	1.0	14	0.73	6.0
10	17	1.1	15	0.65	7.5
15	20	1.2	17	0.59	9.0
20	23	1.3	18	0.55	10.5
25	27	1.4	20	0.51	12.1
50	44	1.8	25	0.40	19.7
75	61	2.1	30	0.34	27.3
100	79	2.4	33	0.30	35.0
125	97	2.6	37	0.28	42.6
150	114	2.9	40	0.30	50.2
175	132	3.1	43	0.24	57.9
200	150	3.3	46	0.23	65.5
275	205	3.9	53	0.20	88.4
300	224	4.0	55	0.19	96.1
400	300	4.7	64	0.17	127.0
500	379	5.3	71	0.15	157.0
600	460	5.9	78	0.14	188.0
700	544	6.5	84	0.13	218.0
800	630	7.1	89	0.13	249.0
900	719	7.6	95	0.12	279.0
1000	810	8.1	100	0.12	310.0
1100	904	8.7	104	0.12	340.0
1200	1000	9.2	109	0.11	371.0
1300	1098	9.7	113	0.11	402.0
1400	1197	10.2	118	0.11	432.0

Note: Capacity Table values established @ base pressure of 14.73 PSIA and base temperature of 60°F; 0.60 specific gravity gas. Supercompressibility included.

3" GT, Output Drive = 1.0 Cubic Meters, 45° Rotor

Line Pressure (bar)	Line Pressure (kPa)	Qmax Sm ³ /h	Qmin Sm ³ /h	Range Qmax/Qmin	Min. Actual Flow Rate Am ³ /h	Press. Drop in mbar
0.02	2	284	24	12	23.5	11.3
0.30	30	365	27	14	21.0	14.3
0.70	70	482	31	16	18.5	18.8
1.00	100	559	33	17	16.8	22.1
2.00	200	841	41	21	13.8	33.1
3.00	300	1124	47	24	12.0	44.2
5.00	500	1694	58	29	9.8	66.3
7.00	700	2270	67	34	8.5	88.4
8.00	800	2559	72	36	8.1	99.5
9.00	900	2851	76	38	7.7	111.0
10.00	1000	3143	80	40	7.3	122.0
12.00	1200	3733	87	43	6.8	144.0
15.00	1500	4626	97	48	6.1	177.0
20.00	2000	6143	112	55	5.4	232.0
30.00	3000	9289	140	66	4.6	343.0
35.00	3500	10,912	153	72	4.3	398.0
40.00	4000	12,581	165	76	4.1	453.0
50.00	5000	16,031	188	85	3.7	564.0
60.00	6000	19,630	211	93	3.5	674.0
70.00	7000	23,387	233	100	3.3	785.0
80.00	8000	27,274	254	107	3.2	895.0
90.00	9000	31,287	275	114	3.1	1006.0
100.00	10,000	35,478	296	120	3.0	1116.0

Note: Capacity Table values established @ base pressure of 101.325 kPa and base temperature of 15°C. Supercompressibility included.

4" GTS and AccuTest, Output Drive = 100 Cubic Feet

Line Pressure (PSIG)	45° Rotor					30° Rotor					AccuTest Reference Rotor	
	Qmax MSCFH	Qmin MSCFH	Range Qmax/Qmin	Min. Actual Flow Rate MACFH	Press. Drop in W.C.	Qmax MSCFH	Qmin MSCFH	Range Qmax/Qmin	Min. Actual Flow Rate MACFH	Press. Drop in W.C.	Range Qmax/Qmin	Min. Actual Flow Rate MACFH
0.25	18	1.2	15	1.20	2.4	23	1.9	12	1.92	3.9	10	1.80
5	24	1.4	17	1.06	3.2	30	2.2	14	1.65	5.2	12	1.50
10	30	1.5	19	0.90	4.0	38	2.5	15	1.48	6.5	13	1.38
15	36	1.7	21	0.85	4.8	46	2.7	17	1.36	7.8	14	1.29
20	42	1.8	23	0.77	5.6	54	2.9	18	1.26	9.1	15	1.20
25	48	2.0	25	0.75	6.4	62	3.1	20	1.18	10.5	17	1.06
50	79	2.5	31	0.58	10.5	101	4.0	25	0.93	17.1	21	0.86
75	111	3.0	37	0.50	14.6	141	4.8	30	0.79	23.7	25	0.72
100	142	3.4	42	0.43	18.7	181	5.4	33	0.70	30.3	27	0.67
125	174	3.8	46	0.40	22.7	222	6.0	37	0.64	36.9	31	0.58
150	206	4.1	50	0.43	26.8	263	6.6	40	0.69	43.5	33	0.55
175	238	4.4	54	0.34	30.9	304	7.1	43	0.55	50.2	36	0.50
200	270	4.7	57	0.41	34.9	346	7.5	46	0.52	56.8	38	0.47
275	370	5.6	66	0.28	47.2	472	8.9	53	0.45	76.6	44	0.41
300	403	5.8	69	0.27	51.2	515	9.3	55	0.44	83.3	46	0.39
400	540	6.8	80	0.24	67.5	690	10.8	64	0.39	110.0	53	0.34
500	682	7.7	89	0.22	83.8	871	12.3	71	0.35	136.0	59	0.31
600	828	8.5	97	0.21	100.0	1057	13.6	78	0.33	163.0	65	0.28
700	978	9.4	104	0.19	116.0	1250	15.0	84	0.31	189.0	70	0.26
800	1134	10.2	112	0.18	133.0	1449	16.2	89	0.29	216.0	74	0.24
900	1294	10.9	118	0.18	149.0	1653	17.5	95	0.28	242.0	79	0.23
1000	1458	11.7	124	0.17	165.0	1864	18.7	100	0.27	269.0	83	0.22
1100	1627	12.5	130	0.17	182.0	2079	19.9	104	0.26	295.0	87	0.21
1200	1800	13.2	136	0.16	198.0	2300	21.1	109	0.26	322.0	91	0.20
1300	1976	13.9	142	0.16	214.0	2525	22.3	113	0.25	348.0	94	0.19
1400	2155	14.7	147	0.15	230.0	2754	23.4	118	0.24	375.0	98	0.18

Note: Capacity Table values established @ base pressure of 14.73 PSIA and base temperature of 60°F; 0.60 specific gravity gas. Supercompressibility included.

4" GTS and AccuTest, Output Drive = 1.0 Cubic Meters

Line Pressure (bar)	Line Pressure (kPa)	45° Rotor					30° Rotor					AccuTest Reference Rotor	
		Qmax Sm³/h	Qmin Sm³/h	Range Qmax/Qmin	Min. Actual Flow Rate Am³/h	Press. Drop in mbar	Qmax Sm³/h	Qmin Sm³/h	Range Qmax/Qmin	Min. Actual Flow Rate Am³/h	Press. Drop in mbar	Range Qmax/Qmin	Min. Actual Flow Rate Am³/h
0.02	2	509	34	15	34	6.0	651	54.1	12	53.9	9.8	10	51.0
0.30	30	657	39	17	30	7.7	841	61.9	14	48.3	12.6	12	42.0
0.70	70	867	45	19	27	10.1	1109	71.4	16	42.6	16.4	13	39.0
1.00	100	1006	48	21	24	11.8	1287	76.4	17	38.7	19.3	14	36.0
2.00	200	1513	59	26	20	17.8	1935	93.7	21	31.7	29.0	17	30.0
3.00	300	2022	68	30	17	23.7	2587	108.5	24	27.5	38.7	20	25.0
5.00	500	3047	83	36	14	35.5	3897	133.5	29	22.5	58.0	24	21.0
7.00	700	4082	97	42	12	47.4	5221	154.9	34	19.6	77.4	28	18.0
8.00	800	4603	103	45	12	53.3	5887	164.6	36	18.5	87.0	30	17.0
9.00	900	5127	109	47	11	59.2	6558	174.0	38	17.6	96.7	32	16.0
10.00	1000	5654	114	49	11	65.1	7231	182.9	40	16.9	106.0	33	15.0
12.00	1200	6714	125	54	10	77.0	8587	199.8	43	15.6	126.0	36	14.0
15.00	1500	8320	140	60	9	94.7	10,641	223.2	48	14.1	155.0	40	13.0
20.00	2000	11,049	162	68	8	124.0	14,132	258.7	55	12.5	203.0	46	11.0
30.00	3000	16,707	201	83	7	184.0	21,368	321.9	66	10.5	300.0	55	9.2
35.00	3500	19,626	220	89	6	213.0	25,101	350.9	72	9.9	348.0	60	8.5
40.00	4000	22,628	237	95	6	243.0	28,941	379.1	76	9.4	397.0	63	8.1
50.00	5000	28,834	271	106	5	302.0	36,878	433.2	85	8.6	493.0	71	7.2
60.00	6000	35,306	303	116	5	361.0	45,155	485.0	93	8.1	590.0	77	6.6
70.00	7000	42,064	335	126	5	420.0	53,799	535.6	100	7.6	687.0	83	6.1
80.00	8000	49,054	366	134	5	480.0	62,740	584.8	107	7.3	783.0	89	5.7
90.00	9000	56,272	396	142	4	539.0	71,970	632.9	114	7.0	880.0	95	5.4
100.00	10,000	63,810	426	150	4	598.0	81,612	681.2	120	6.8	977.0	100	5.1

Note: Capacity Table values established @ base pressure of 101.325 kPa and base temperature of 15°C. Supercompressibility included.

6" GTS and AccuTest, Output Drive = 100 Cubic Feet

Line Pressure (PSIG)	45° Rotor					30° Rotor					AccuTest Reference Rotor	
	Qmax MSCFH	Qmin MSCFH	Range Qmax/Qmin	Min. Actual Flow Rate MACFH	Press. Drop in W.C.	Qmax MSCFH	Qmin MSCFH	Range Qmax/Qmin	Min. Actual Flow Rate MACFH	Press. Drop in W.C.	Range Qmax/Qmin	Min. Actual Flow Rate MACFH
0.25	35	1.9	18	1.94	3.3	50	3.3	15	3.34	6.7	10	3.50
5	46	2.2	21	1.69	4.4	66	3.8	17	2.90	8.9	12	2.92
10	58	2.5	23	1.51	5.5	83	4.3	19	2.59	11.2	13	2.70
15	70	2.8	25	1.38	6.6	100	4.7	21	2.36	13.5	14	2.50
20	82	3.0	28	1.27	7.7	117	5.1	23	2.18	15.8	15	2.33
25	94	3.2	29	1.19	8.8	134	5.5	25	2.03	18.1	17	2.06
50	154	4.1	38	0.94	14.4	220	7.0	31	1.59	29.7	21	1.07
75	215	4.8	44	0.80	20.0	307	8.3	37	1.34	41.4	25	1.40
100	276	5.5	50	0.71	25.6	394	9.4	42	1.19	53.2	27	1.30
125	338	6.1	55	0.64	31.2	483	10.5	47	1.07	65.0	31	1.13
150	400	6.7	60	0.70	36.8	572	11.4	51	0.99	77.0	33	1.06
175	463	7.2	65	0.56	42.4	661	12.3	55	0.92	89.0	36	0.97
200	526	7.7	69	0.53	48.1	751	13.1	58	0.86	101.0	38	0.92
275	719	9.0	80	0.46	64.9	1026	15.4	68	0.74	138.0	44	0.80
300	784	9.4	83	0.44	70.5	1120	16.2	71	0.70	151.0	46	0.76
400	1050	11.0	95	0.39	92.9	1500	18.9	82	0.61	202.0	53	0.66
500	1325	12.5	106	0.36	115.0	1893	21.4	92	0.54	256.0	59	0.59
600	1609	13.8	116	0.33	138.0	2299	23.7	102	0.49	310.0	65	0.54
700	1903	15.2	125	0.31	160.0	2718	26.0	111	0.45	367.0	70	0.50
800	2205	16.5	134	0.30	182.0	3150	28.2	119	0.42	426.0	74	0.47
900	2516	17.7	142	0.29	205.0	3594	30.4	127	0.39	486.0	79	0.44
1000	2836	19.0	149	0.28	227.0	4051	32.5	135	0.37	549.0	83	0.42
1100	3164	20.2	157	0.27	250.0	4520	34.6	143	0.35	613.0	87	0.40
1200	3500	21.4	163	0.26	272.0	5000	36.7	151	0.33	678.0	91	0.38
1300	3842	22.6	170	0.26	294.0	5488	38.7	158	0.32	745.0	94	0.37
1400	4190	23.8	176	0.25	317.0	5986	40.7	165	0.30	814.0	98	0.35

Note: Capacity Table values established @ base pressure of 14.73 PSIA and base temperature of 60°F; 0.60 specific gravity gas. Supercompressibility included.

6" GTS and AccuTest, Output Drive = 1.0 Cubic Meters

Line Pressure (bar)	Line Pressure (kPa)	45° Rotor					30° Rotor					AccuTest Reference Rotor	
		Qmax Sm³/h	Qmin Sm³/h	Range Qmax/Qmin	Min. Actual Flow Rate Am³/h	Press. Drop in mbar	Qmax Sm³/h	Qmin Sm³/h	Range Qmax/Qmin	Min. Actual Flow Rate Am³/h	Press. Drop in mbar	Range Qmax/Qmin	Min. Actual Flow Rate Am³/h
0.02	2	1000	55	18	55	8.2	1440	95.7	15	95.0	16.9	10	100
0.30	30	1291	63	20	49	10.5	1836	108.0	17	84.1	21.5	12	83
0.70	70	1703	73	23	44	13.7	2403	123.6	19	73.5	28.2	13	77
1.00	100	1977	78	25	40	16.2	2829	134.1	21	67.8	33.2	14	71
2.00	200	2972	96	31	32	24.3	4253	164.4	26	55.3	49.9	17	59
3.00	300	3973	111	36	28	32.4	5679	190.0	30	47.8	66.6	20	50
5.00	500	5986	137	44	23	48.5	8570	233.4	37	38.9	101.0	24	42
7.00	700	8020	159	51	20	64.7	11,473	270.0	42	33.7	135.0	22	36
8.00	800	9043	169	54	19	72.8	12,956	287.0	45	31.7	152.0	30	33
9.00	900	10,073	178	57	18	80.9	14,409	302.6	48	30.0	169.0	32	31
10.00	1000	11,107	187	59	17	89.0	15,902	317.9	50	28.6	187.0	33	30
12.00	1200	13,190	205	64	16	105.0	18,875	346.4	54	26.2	221.0	36	28
15.00	1500	16,346	229	72	14	129.0	23,258	384.5	60	23.6	273.0	40	25
20.00	2000	21,708	265	82	13	170.0	31,119	444.7	70	20.4	365.0	46	21
30.00	3000	32,823	330	100	11	251.0	46,813	545.5	86	16.7	549.0	55	18
35.00	3500	38,558	359	107	10	291.0	55,176	592.2	93	15.4	647.0	60	17
40.00	4000	44,455	388	114	10	332.0	63,881	637.2	100	14.3	749.0	63	16
50.00	5000	56,648	444	128	9	413.0	81,261	718.7	113	12.7	953.0	71	14
60.00	6000	69,363	497	140	8	494.0	99,691	796.0	125	11.4	1169.0	77	13
70.00	7000	82,640	548	151	8	575.0	118,499	867.8	137	10.5	1390.0	83	12
80.00	8000	96,374	599	161	7	655.0	138,322	937.6	148	9.7	1622.0	89	11
90.00	9000	110,554	648	171	7	736.0	159,214	1005.9	158	9.0	1867.0	95	11
100.00	10,000	125,364	698	180	7	817.0	180,742	1071.8	169	8.5	2119.0	100	10

Note: Capacity Table values established @ base pressure of 101.325 kPa and base temperature of 15°C. Supercompressibility included.

8" GTS and AccuTest, Output Drive = 1000 Cubic Feet

Line Pressure (PSIG)	45° Rotor					30° Rotor					AccuTest Reference Rotor	
	Qmax MSCFH	Qmin MSCFH	Range Qmax/Qmin	Min. Actual Flow Rate MACFH	Press. Drop in W.C.	Qmax MSCFH	Qmin MSCFH	Range Qmax/Qmin	Min. Actual Flow Rate MACFH	Press. Drop in W.C.	Range Qmax/Qmin	Min. Actual Flow Rate MACFH
0.25	60	3.0	20	3.00	1.6	88	5.9	15	5.87	3.4	10	6.00
5	79	3.4	23	2.61	2.1	116	6.7	17	5.11	4.5	12	5.00
10	99	3.9	26	2.33	2.7	146	7.6	19	4.56	5.7	13	4.62
15	120	4.2	28	2.13	3.2	176	8.3	21	4.16	6.8	14	4.28
20	141	4.6	31	1.97	3.7	206	9.0	23	3.85	8.0	15	4.00
25	161	4.9	33	1.84	4.3	236	9.6	25	3.60	9.1	17	3.53
50	264	6.3	42	1.45	7.0	388	12.4	31	2.83	14.9	21	2.86
75	368	7.5	49	1.23	9.7	540	14.6	37	2.41	20.7	25	2.40
100	473	8.5	56	1.09	12.4	694	16.6	42	2.14	26.4	27	2.22
125	579	9.4	62	0.99	15.2	850	18.4	46	1.95	32.2	31	1.96
150	686	10.3	67	1.08	17.9	1006	20.1	50	2.11	38.0	33	1.82
175	793	11.1	72	0.86	20.6	1164	21.6	54	1.68	43.7	36	1.67
200	901	11.8	76	0.81	23.3	1322	23.1	57	1.59	49.5	38	1.58
275	1232	13.9	89	0.71	31.4	1807	27.2	66	1.38	66.8	44	1.36
300	1344	14.5	92	0.68	34.2	1971	28.4	69	1.33	72.6	46	1.30
400	1800	17.0	106	0.60	45.0	2640	33.2	80	1.18	95.7	53	1.13
500	2272	19.2	118	0.55	55.9	3332	37.6	89	1.08	119.0	59	1.02
600	2759	21.4	129	0.51	66.7	4046	41.8	97	1.00	142.0	65	0.92
700	3262	23.4	139	0.48	77.6	4784	45.8	104	0.95	165.0	70	0.86
800	3780	25.4	149	0.46	88.5	5543	49.7	112	0.90	188.0	74	0.81
900	4313	27.4	158	0.44	99.3	6326	53.5	118	0.87	211.0	79	0.76
1000	4862	29.3	166	0.43	110.0	7130	57.3	124	0.84	234.0	83	0.72
1100	5424	31.2	174	0.41	121.0	7955	61.0	130	0.81	257.0	87	0.69
1200	6000	33.0	182	0.40	132.0	8799	64.6	136	0.79	280.0	91	0.66
1300	6586	34.9	189	0.39	143.0	9659	68.2	142	0.77	303.0	94	0.64
1400	7183	36.7	196	0.38	154	10535	71.7	147	0.75	326.0	98	0.61

Note: Capacity Table values established @ base pressure of 14.73 PSIA and base temperature of 60°F; 0.60 specific gravity gas. Supercompressibility included.

8" GTS and AccuTest, Output Drive = 10.0 Cubic Meters

Line Pressure (bar)	Line Pressure (kPa)	45° Rotor					30° Rotor					AccuTest Reference Rotor	
		Qmax Sm³/h	Qmin Sm³/h	Range Qmax/Qmin	Min. Actual Flow Rate Am³/h	Press. Drop in mbar	Qmax Sm³/h	Qmin Sm³/h	Range Qmax/Qmin	Min. Actual Flow Rate Am³/h	Press. Drop in mbar	Range Qmax/Qmin	Min. Actual Flow Rate Am³/h
0.02	2	1700	85.0	20	84	4.0	2500	166.3	15	165.5	8.7	10	170
0.30	30	2195	97.0	23	76	5.1	3228	190.1	17	148.4	11.1	12	142
0.70	70	2895	112.0	26	67	6.7	4257	219.2	19	130.8	14.6	13	131
1.00	100	3360	120.0	28	61	7.9	4942	234.6	21	119.0	17.2	14	121
2.00	200	5053	147.0	34	50	11.8	7431	288.0	26	97.3	25.7	17	100
3.00	300	6755	170.0	40	43	15.8	9933	333.4	30	84.5	34.3	20	85
5.00	500	10,176	209.0	49	35	23.7	14,965	410.0	36	69.3	51.5	24	71
7.00	700	13,635	243.0	56	31	31.6	20,051	475.8	42	60.3	68.7	28	61
8.00	800	15,373	258.0	60	29	35.5	22,607	505.8	45	57.0	77.3	30	57
9.00	900	17,125	273.0	63	28	39.5	25,184	534.5	47	54.2	85.8	32	53
10.00	1000	18,882	287.0	66	26	43.4	27,768	561.9	49	51.8	94.4	33	52
12.00	1200	22,423	313.0	72	24	51.3	32,974	613.8	54	47.8	112.0	36	47
15.00	1500	27,788	350.0	79	22	63.2	40,865	685.6	60	43.4	137.0	40	43
20.00	2000	36,903	405.0	91	20	82.9	54,269	794.8	68	38.4	180.0	46	37
30.00	3000	55,799	504.0	111	16	122.0	82,057	989.0	83	32.3	266.0	55	31
35.00	3500	65,548	550.0	119	15	142.0	96,394	1078.2	89	30.3	309.0	60	28
40.00	4000	75,574	594.0	127	15	162.0	111,139	1164.8	95	28.8	352.0	63	27
50.00	5000	96,301	679.0	142	13	201.0	141,619	1330.8	106	26.4	438.0	71	24
60.00	6000	117,917	760.0	155	13	241.0	173,407	1490.0	116	24.8	524.0	77	22
70.00	7000	140,488	839.0	167	12	280.0	206,600	1645.4	126	23.5	610.0	83	20
80.00	8000	163,836	916.0	179	11	320.0	240,936	1796.5	134	22.5	695.0	89	19
90.00	9000	187,941	992.0	190	11	359.0	276,384	1944.3	142	21.6	781.0	95	18
100.00	10,000	213,119	1067.0	200	11	399.0	313,410	2092.8	150	21.0	867.0	100	17

Note: Capacity Table values established @ base pressure of 101.325 kPa and base temperature of 15°C. Supercompressibility included.

12" GT, Output Drive = 1000 Cubic Feet, 45° Rotor

Line Pressure (PSIG)	Qmax MSCFH	Qmin MSCFH	Range Qmax/Qmin	Min. Actual Flow Rate MACFH	Press. Drop in W.C.
0.25	150	6.0	25	6.00	2.1
5	198	6.9	29	5.22	2.8
10	249	7.7	32	4.66	3.5
15	300	8.5	35	4.25	4.2
20	351	9.2	38	3.93	4.9
25	403	9.9	41	3.68	5.6
50	661	12.6	52	2.89	9.2
75	921	15.0	62	2.46	12.8
100	1183	17.0	70	2.19	16.3
125	1448	18.8	77	1.99	19.9
150	1715	20.5	84	2.16	23.4
175	1983	22.1	90	1.72	27.0
200	2254	23.6	95	1.62	30.6
275	3079	27.8	111	1.41	41.3
300	3359	29.1	116	1.36	44.8
400	4500	33.9	133	1.21	59.1
500	5680	38.4	148	1.10	73.3
600	6897	42.7	161	1.03	87.6
700	8154	46.8	174	0.97	102.0
800	9449	50.8	186	0.92	116.0
900	10783	54.7	197	0.89	130.0
1000	12154	58.6	207	0.86	145.0
1100	13560	62.4	217	0.83	159.0
1200	14999	66.1	227	0.81	173.0
1300	16465	69.7	236	0.79	187.0
1400	17958	73.3	245	0.76	202.0

Note: Capacity Table values established @ base pressure of 14.73 PSIA and base temperature of 60°F; 0.60 specific gravity gas. Supercompressibility included.

12" GT, Output Drive = 10.0 Cubic Meters, 45° Rotor

Line Pressure (bar)	Line Pressure (kPa)	Qmax Sm ³ /h	Qmin Sm ³ /h	Range Qmax/Qmin	Min. Actual Flow Rate Am ³ /h	Press. Drop in mbar
0.02	2	4289	171	25	170	5.2
0.30	30	5512	195	28	152	6.7
0.70	70	7269	225	32	134	8.7
1.00	100	8438	240	35	122	10.3
2.00	200	12,689	295	43	100	15.4
3.00	300	16,962	342	50	87	20.5
5.00	500	25,554	420	61	71	30.8
7.00	700	34,239	487	70	62	41.0
8.00	800	38,604	518	74	58	46.2
9.00	900	43,004	548	79	55	51.3
10.00	1000	47,416	576	82	53	56.4
12.00	1200	56,307	629	90	49	66.7
15.00	1500	69,782	702	99	44	82.1
20.00	2000	92,670	814	114	39	108.0
30.00	3000	140,121	1013	138	33	159.0
35.00	3500	164,603	1105	149	31	185.0
40.00	4000	189,780	1193	159	29	210.0
50.00	5000	241,829	1363	177	27	262.0
60.00	6000	296,110	1527	194	25	313.0
70.00	7000	352,790	1686	209	24	364.0
80.00	8000	411,422	1841	224	23	416.0
90.00	9000	471,954	1992	237	22	467.0
100.00	10,000	535,179	2144	250	22	518.0

Note: Capacity Table values established @ base pressure of 101.325 kPa and base temperature of 15°C. Supercompressibility included.

GT, GTS, GTX and AccuTest Turbine Gas Meters - Other Technical Data

Turbine Meter Dimensional Table

	MAOP			Meter Dimensions				Flange O.D.	Bolt Circle	Flange Bolts		Hole Size	ANSI	Shipping Weight
	PSIG	Bar	kPa	A	B	B (E-Class)	C			No.	Dia.			
3" GT	275			9.18"	6.52"									10 lbs
	1480			11.26"	6.52"									20 lbs
		19	1900	233 mm	166 mm									4.5 kg
		100	10,200	286 mm	166 mm									9.0 kg
4" GTS GTX AccuTest	175			10.78"	14.00"	14.00"	NA	9.00"	7.50"	8	5/8"		150 FF	32 lbs
	740			10.78"	14.00"	15.50"	.06"	10.00"	7.87"	8	3/4"		300 RF	150 lbs
	1480			10.78"	14.00"	15.50"	.25"	10.75"	8.50"	8	7/8"		600 RF	150 lbs
		12	1200	274 mm	356 mm	356 mm	NA	229 mm	190 mm	8		19 mm	150 FF	14.5 kg
		50	5000	274 mm	356 mm	394 mm	1.5 mm	254 mm	200 mm	8		22 mm	300 RF	68 kg
		100	10,200	274 mm	356 mm	394 mm	6.4 mm	273 mm	216 mm	8		25 mm	600 RF	68 kg
6" GTS GTX AccuTest	175			11.85"	16.00"	16.00"	NA	11.00"	9.50"	8	3/4"		150 FF	54 lbs
	740			11.85"	18.00"	22.50"	.06"	12.50"	10.62"	12	3/4"		300 RF	275 lbs
	1480			12.34"	18.00"	NA	.25"	14.00"	11.50"	12	1"		600 RF	275 lbs
		12	1200	301 mm	410 mm	410 mm	NA	279 mm	241 mm	8		22 mm	150 FF	24.5 kg
		50	5000	301 mm	460 mm	572 mm	1.5 mm	318 mm	270 mm	12		22 mm	300 RF	125 kg
		100	10,200	313 mm	460 mm	NA	6.4 mm	356 mm	292 mm	12		29 mm	600 RF	125 kg
8" GTS GTX AccuTest	175			12.97"	21.00"	21.00"	NA	13.50"	11.75"	8	3/4"		150 FF	90 lbs
	740			12.97"	23.00"	27.25"	.06"	15.00"	13.00"	12	7/8"		300 RF	450 lbs
	1480			13.47"	23.00"	NA	.25"	16.50"	13.75"	12	1 1/8"		600 RF	450 lbs
		12	1200	329 mm	535 mm	535 mm	NA	343 mm	298 mm	8		22 mm	150 FF	47 kg
		50	5000	329 mm	585 mm	693 mm	1.5 mm	381 mm	330 mm	12		25 mm	300 RF	205 kg
		100	10,200	342 mm	585 mm	NA	6.4 mm	419 mm	349 mm	12		32 mm	600 RF	205 kg
12" GT	175			20.00"	29.00"	NA	.06"	19.00"	17.00"	12	7/8"		150 FF	460 lbs
	275			20.00"	29.00"	NA	.06"	19.00"	17.00"	12	7/8"		150 RF	490 lbs
	740			20.57"	30.25"	NA	.06"	20.50"	17.75"	16	1 1/8"		300 RF	620 lbs
	1480			21.00"	32.75"	NA	.25"	22.00"	19.50"	20	1 1/4"		600 RF	970 lbs
		12	1200	508 mm	740 mm	NA	1.5 mm	483 mm	432 mm	12		25 mm	150 FF	209 kg
		19	1900	508 mm	740 mm	NA	1.5 mm	483 mm	432 mm	12		25 mm	150 RF	222 kg
		51	5000	522 mm	770 mm	NA	1.5 mm	521 mm	451 mm	16		32 mm	300 RF	280 kg
		102	10,200	533 mm	832 mm	NA	6.4 mm	559 mm	495 mm	20		35 mm	600 RF	440 kg

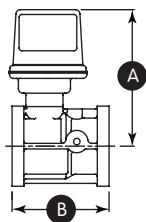

3" GT Turbine Meter

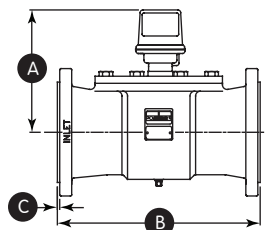

4", 6" & 8" GTS and GTX and AccuTest Turbine Meter

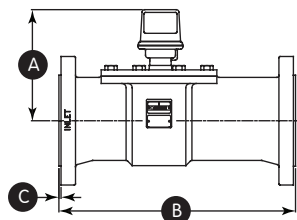

4", 6" & 8" GTS and GTX E-Class Turbine Meter

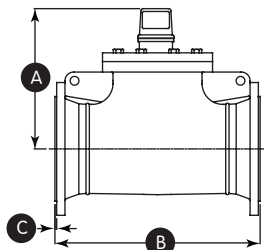

12" GT Turbine Meter

Ordering Information

- 1 Size
- 2 Model
- 3 Working pressure/Housing length
- 4 Standard or extended capacity (30° or 45° Rotor)
- 5 Drive Output (English or Metric)
- 6 Index (Pointer or Odometer)
- 7 Options

About Elster Group

A world leader in advanced metering infrastructure, integrated metering, and utilization solutions to the gas, electricity and water industries. Elster's metering and system solutions reflect over 170 years of knowledge and experience in measuring precious resources and energy.

Elster provides solutions and advanced technologies to help utilities more easily, efficiently and reliably obtain and use advanced metering intelligence to improve customer service, enhance operational efficiency, and increase revenues. Elster's AMI solutions enable utilities to cost-effectively generate, deliver, manage, and conserve the life-essential resources of gas, electricity, and water.

Elster has a staff of over 7,500 serving customers globally in North America, Central America, South America, Europe, Asia, Africa and the Middle East.

ISO 9001:2000



Certification No. 006697

Distributed By:



IMAC Systems, Inc
90 Main Street, PO Box 1605
Tullytown, PA. 19007

1-800-955-4GAS
Phone: (215) 946-2200
Fax: (215) 943-2984

sales@imacsystems.com